



ICE CREAM ROLL MACHINE

COUNTER DROP-IN - ICE PAN / ICE TEPPAN / ROLLED ICE CREAM MACHINE

Function: Ice Pan to create ice cream rolls.

Dimensions: Working area of 450x450mm. 355mm tall. See technical drawing for cut-out size.

Weight: Approx 35kg.

Construction: Multi-layer plate with cooling coils.

Electrics: CE rated. 220-240v 50Hz. Peak power 1100w.

Controller: 1m controller cable. 1.5m power cable.

Temperature Range: -15°C to -30°C continuously adjustable.

Accessories: 1x Pair of Ice Roll Pro Scrapers included. Accessory packages available. Online training videos included. Onsite training available.

Warranty & Guarantee: 24 month warranty. Guaranteed to operate in +38°C ambient temperature.

Special Requirements: Supply and exhaust ventilation required. Approved fan kits available.

Refrigerant: R290. Approx 80g.



- icerollpro.com
- (+44) 0333 335 5382
- info@icerollpro.com
- Unit 57 Spaces Business Centre, 15-17 Ingate Place, London SW8 3NS, UK.



@icerollpro



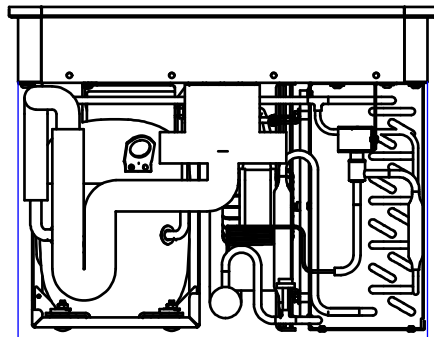

460 MM - THE MOUNTING HOLE SHOULD BE 465 X 465 MM

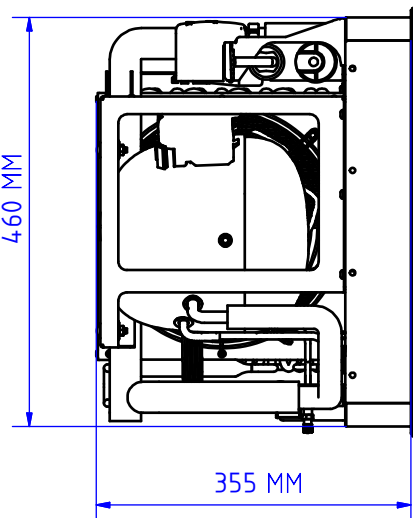
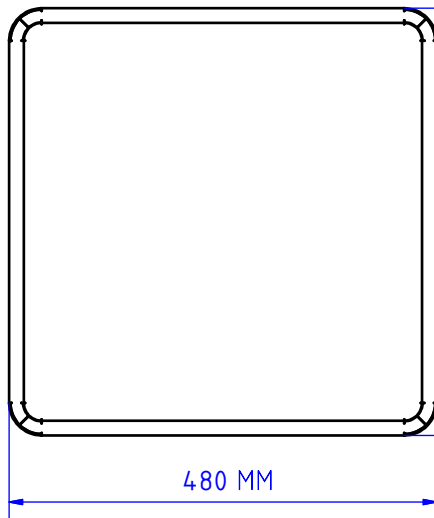

DEPTH OF 455 MM UNDER COUNTER REQUIRED

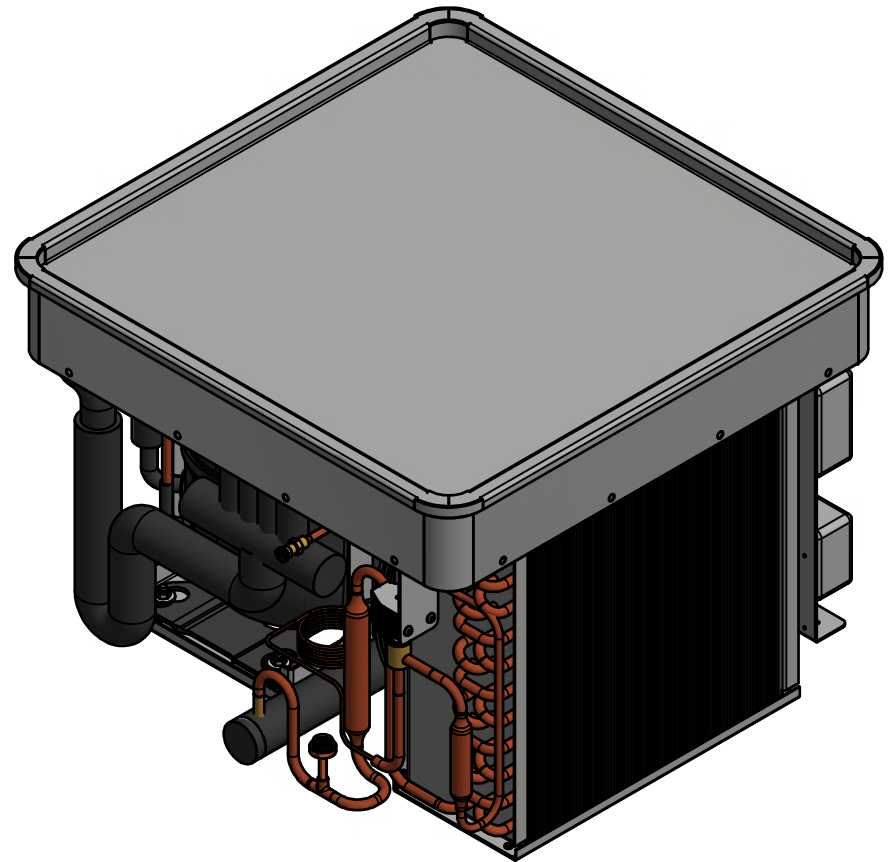

info@icerollpro.com
icerollpro.com

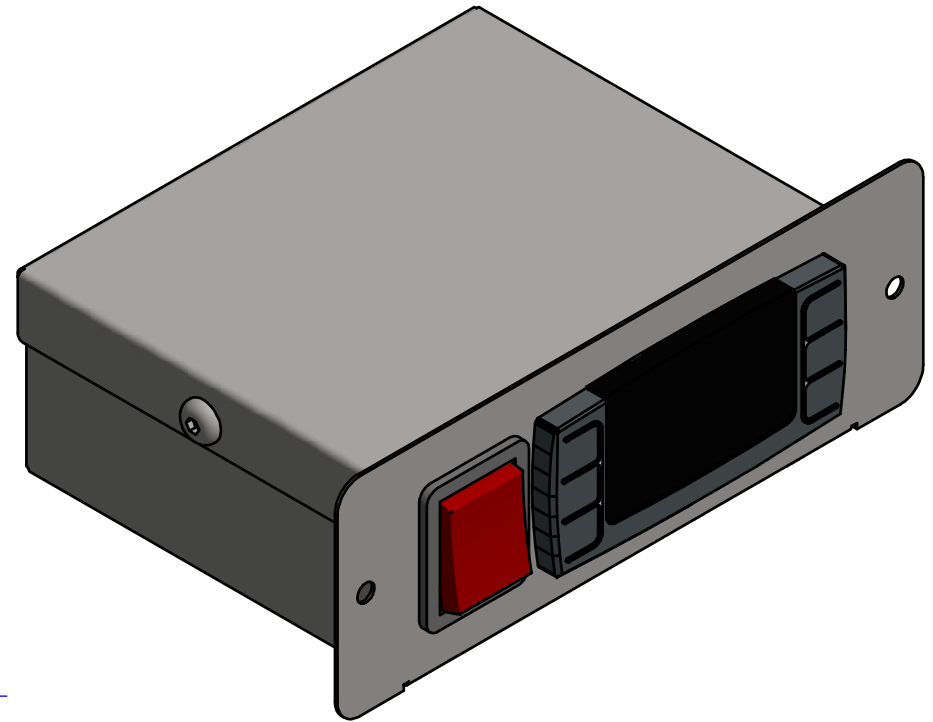
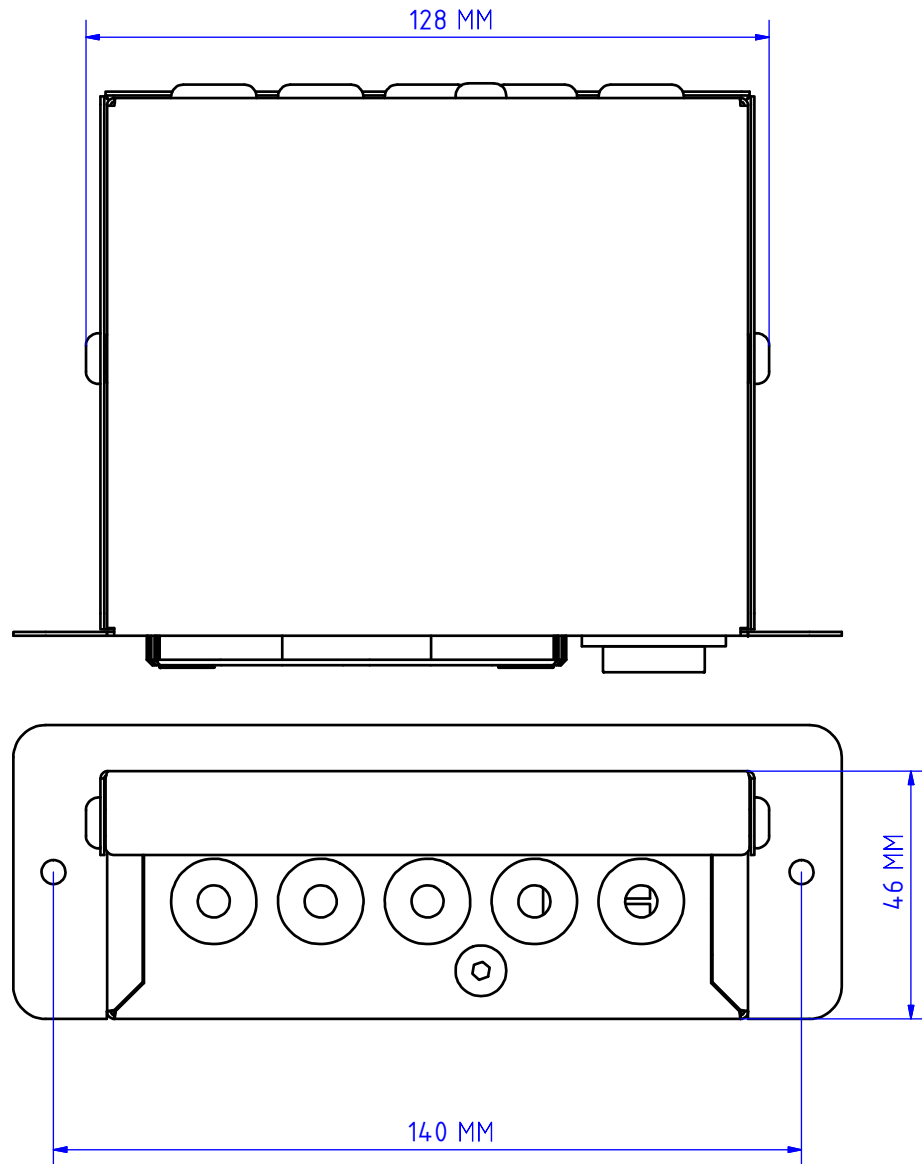

COMMENTS:

1. The mounting hole for the control panel should have the dimensions: 130 x 50 mm



info@icerollpro.com
icerollpro.com